

COMPREHENSIVE ANALYSIS OF 2-PAM MODULATED WDM ROF SYSTEM FOR VISUAL COMMUNICATION LINKS

Sunny Deshwal

Research Scholar, School of Engineering and Technology

Monad University, Hapur, (U. P.) India.

Dr. Anshu Tyagi

Research Supervisor, School of Engineering and Technology

Monad University, Hapur, (U. P.) India.

Abstract:

The execution of radio over fiber network can be further enhanced by using several techniques such as, wavelength division multiplexing, time division multiplexing, orthogonal frequency division multiplexing, optical code-division multiple access, wavelength reuse scheme, etc. Radio over fiber is a potential solution to meet up with the growing internet bandwidth demand. It is a spectacular combination of both optical and wireless communication. A radio over fiber system supports convergent network architecture by exploiting the benefits of both optical and wireless technologies and provides multiple services to both mobile and fixed users. The main objective is to analyze the performance of radio over fiber system when integrated with PAM modulation scheme. It was applied to optical network system to overcome the non-linearity effect such as the signal loss. The use of erbium doped fiber amplifier has been investigated to improve the quality of the transmission system. Here the execution of radio over fiber network is investigated and is further improved by integrating radio over fiber with 2-PAM modulation scheme.

Key Word:- Radio over Fiber, WDM, Pulse Amplitude modulation, Intensity modulation Direct Detection.

I. INTRODUCTION

Optical fiber communication involves transmission of data from one place to other using pulses of light that are sent through an optical fiber. An electromagnetic carrier wave is formed by light which is modulated to carry information. The global internet protocol traffic is growing at a massive pace and it is expected to cross the zetabyte threshold. This growing demand for high data rate communication system has heralded optical fiber communication system as the potential solution. Optical communication was first developed in the 1970s and since then it has not only revolutionized the telecommunications industry but also played a crucial role in the initiation of the Information Age. The main benefit provided by optical communication is extremely broad bandwidth which is associated with an optical carrier. The optical carrier frequency (~100 THz) is greater than the microwave carrier frequency (~1 GHz) by five orders of magnitude. Since, the modulation bandwidth is limited usually to a small fraction of carrier frequency in digital systems, it roughly translates to 100,000 times more capacity for an optical fiber communication system. Many studies had been conducted in relation to Orthogonal Frequency Division Multiplexing (OFDM), Radio over Fiber (RoF) and Wavelength-Division Multiplexing (WDM) networking to transform something that can improve the efficiency on high speed and low cost accessing networks. All the researchers need to face great challenges on designing a quality access networks that can meet the above criteria for the needs of consumers in terms of speed and efficiency data transmission. Therefore, the understanding of each component in the access network such as OFDM, WDM and RoF are in urgent great demand. Wavelength-Division Multiplexing (WDM) is a multiplexing technique for fiber optic system to multiplex a number of optical carrier signals onto a single optical fiber by using different wavelengths. Radio over Fiber (RoF) refers to a technology whereby light is modulated by a radio signal and transmitted over an optical fiber link to facilitate wireless access. Although radio transmission over fiber serves as multiple purposes in cable television (CATV) networks and satellite base stations, the term RoF is usually applied where there is wireless access. RoF has made cost-effective, high-data-rate mobile wireless broadband networks, an inherent immunity to electromagnetic interference and reduction on power consumption. Moreover, it provides a huge bandwidth which is convenience for installation and maintenance at ease operational flexibility. Apart from that, this system is designed for the compatibility to the wave-multiplexing (WDM) and the wave-division-multiplexing passive optical networks (WDM-PON). It also works well on

flexibility to both wired and wireless users at the same time for using the same optical infrastructure which is distributed to its customers.

II. THEORETICAL FRAMEWORK

Intensity Modulation Direct Detection Technique:

There are various optical techniques to generate and transport radio signals through optical fiber. In terms of modulation/demodulation format, it is classified into two categories that are, intensity modulation-direct detection and remote heterodyne detection. Here Intensity Modulation-Direct Detection is used which involves modulation of light source intensity directly with RF signal. DD is performed by photodetector for recovering the RF signal. Modulation of laser can occur by two methods. In first method, direct modulation of laser occurs using RF signal for driving the laser bias current. This has been depicted in figure 1. Other method involves operation of laser in continuous wave followed by modulation of light intensity by external modulator (for example, Mach Zehnder modulator) as shown in figure 1.

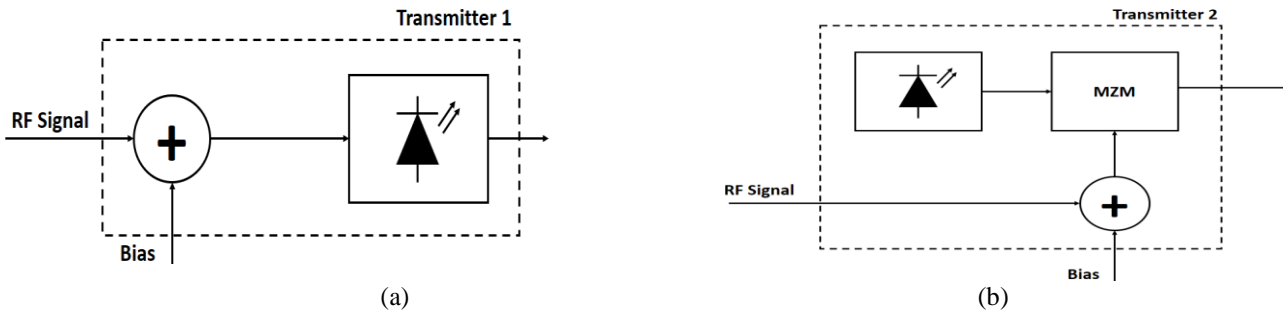

Fig.1. Intensity modulation-direct detection technique (a) directly modulated RF signal (b) using external modulator

Wavelength Division Multiplexing:

Wavelength Division Multiplexing (WDM) refers to a technique that combines several optical carrier signals on a single optical fiber link by using different wavelengths of light source. Thus, a different frequency is allocated to each communication channel followed by multiplexing and transmission on a single fiber.

Pulse Amplitude Modulation:

In pulse amplitude modulation, the amplitude of a carrier consisting of a periodic train of rectangular pulses is varied in proportion to sample values of a message signal. In this type of modulation, the pulse duration is held constant. By making the amplitude of each rectangular pulse the same as the value of the message signal at the leading edge of the pulse, the version of PAM is exactly the same as flat top sampling

III. SYSTEM DESIGN

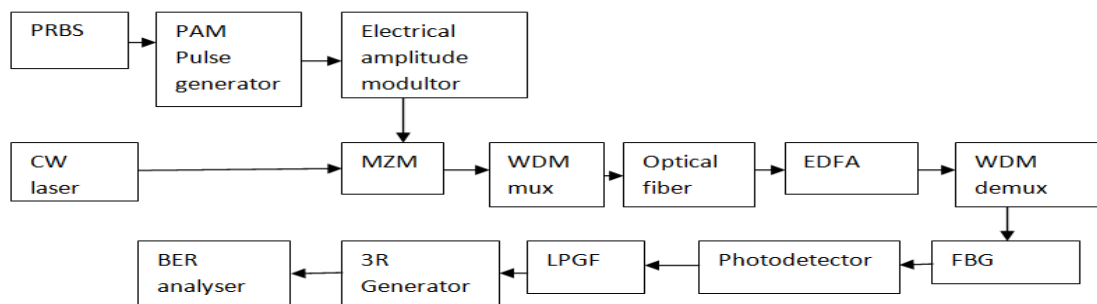

Fig.2. Block diagram of 2- PAM modulated WDM Radio over Fiber for Optical Networks

At the transmitter, the binary data supplied by the pseudorandom bit sequence is converted into electrical pulses by using pulse amplitude modulator with $M=2$. The carrier frequency of the pulse amplitude modulator is 10 MHz which can be used to convert the frequency of the baseband signal to the RF clock frequency. The continuous wave laser generates a continuous wave optical signal. The Mach Zehnder modulator is used for the transmission of microwave signals to optical signals. Wavelength Division Multiplexer is used to multiplex all signals from the transmitter. Then the optically modulated

signal is passed through a single mode fiber channel. The attenuation factor value can be chosen with 0.2 dB/km. The utilisation of EDFA amplifier in this system creates a lot of advantages such as the low noise figure and has independent polarisation which boosts the power of the optical signal. As soon as the signal reaches the receiver side, WDM demultiplexer is used to demultiplex the signals before the signals being distributed to the own receivers. Ideal Dispersion Compensation FBG is used to compensate the dispersion effects. After that photodetector is used to convert the optical signal into electrical form and then the signal was filtered using the Bandpass Bessel Filter and demodulated using the demodulator. 3R generator technique is applied to the signal before the BER analyser analyses the received signal.

IV. SIMULATION SETUP

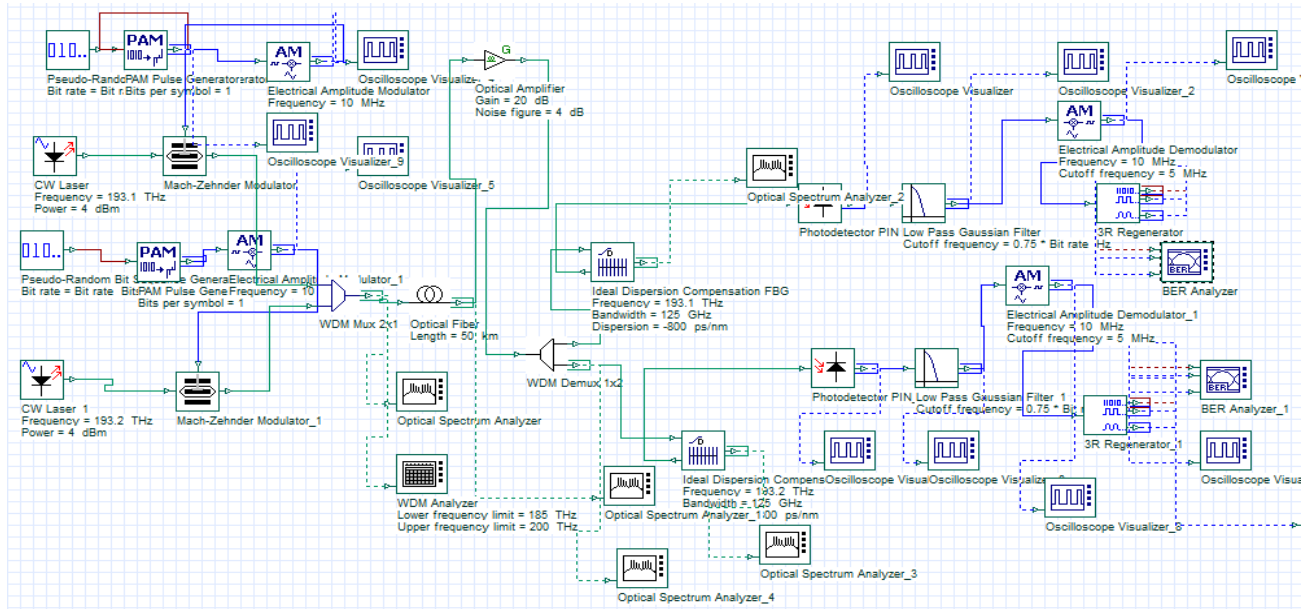

Fig.3. Simulation diagram for 2- PAM modulated WDM Radio over Fiber

Table 1. Simulation parameters of system

Parameters	Value
Frequency	193.1 THz, 193.2 THz
Optical CW Launch Power	-5,-3,-1,0,1,3,5dBm
Extinction ratio	30 dB
Optical modulator	Mach Zehnder Modulator
Photodetector	APD
Length	10,20,40 Km
Bits per symbol	M=2 (2-PAM)
Dispersion	16 ps/nm/km
Attenuation	0.2 dB/km
Bit Rate	10 Gbps

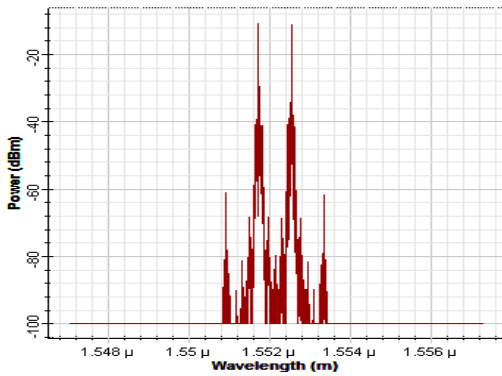

Fig.4. Transmission of WDM signal through optical fiber

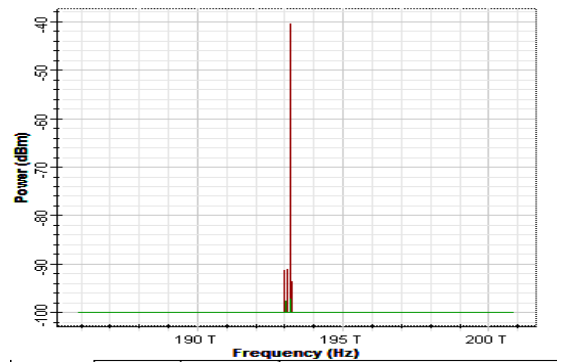

Fig.5. Wavelength reflected by FBG1

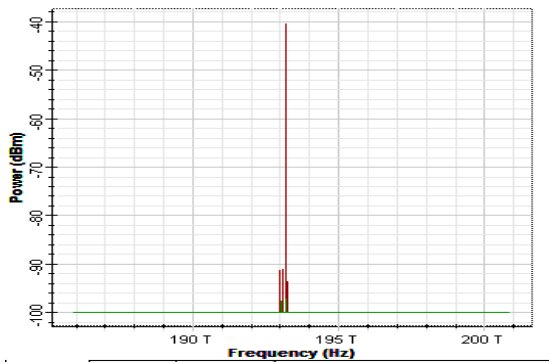

Fig.6. Wavelength reflected by FBG2 demodulation

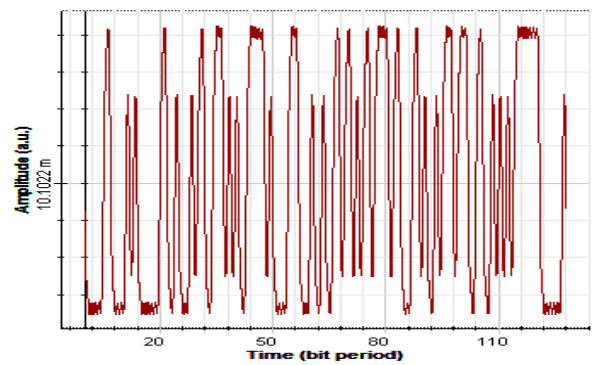

Fig.7. Received signal after

V RESULTS AND DISCUSSION:

After the simulation is done, the performance of the receiver is analysed by referring the BER analyser and the eye diagram of two receivers. For receiver 1, the BER analyser shows that the BER for the received signal is $1.17E-010$. The Q factor for the receiver is 6.328. This shows that this receiver has a very good performance since the number of BER is above $E-009$ and the Q factor is more than 6. Figure 8 and Figure 9 shows the Q factor result and Eye Diagram for receiver 1 respectively.

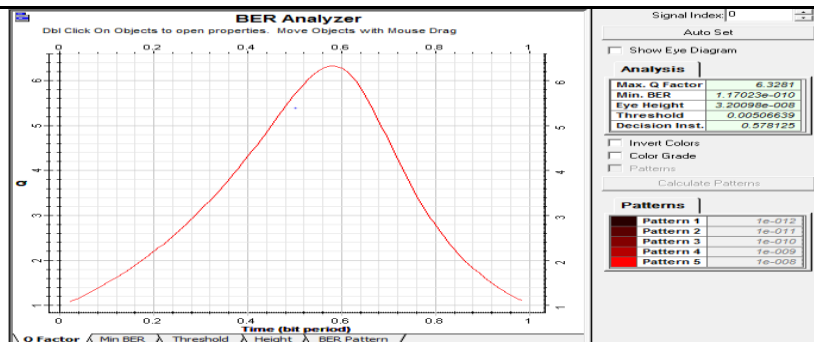

Fig.8. Q factor result for receiver 1

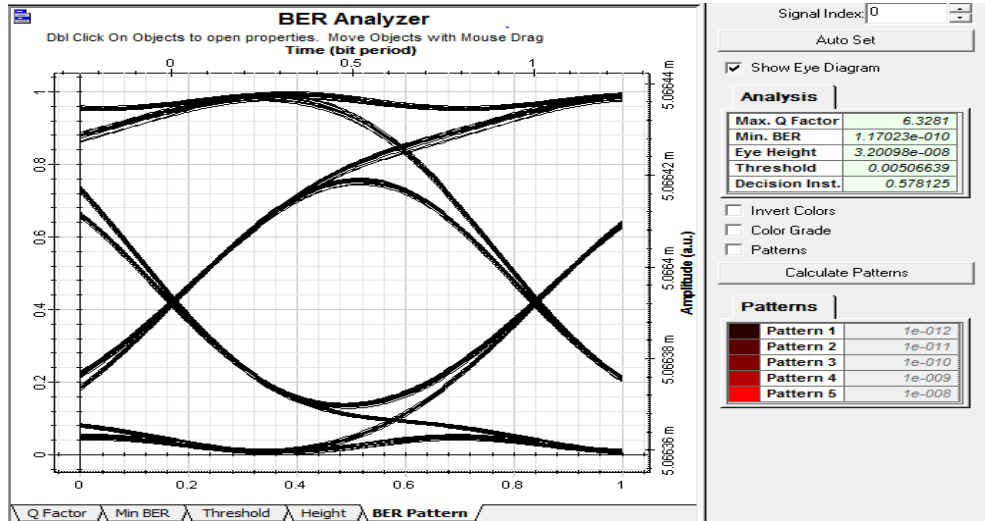

Fig.9. Eye diagram for receiver 1

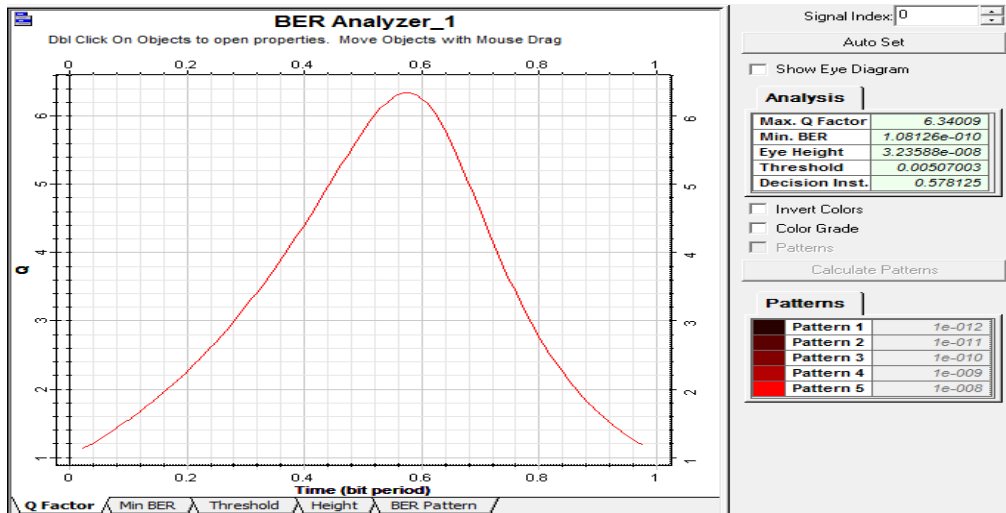

Fig.10. Q factor result for receiver 2

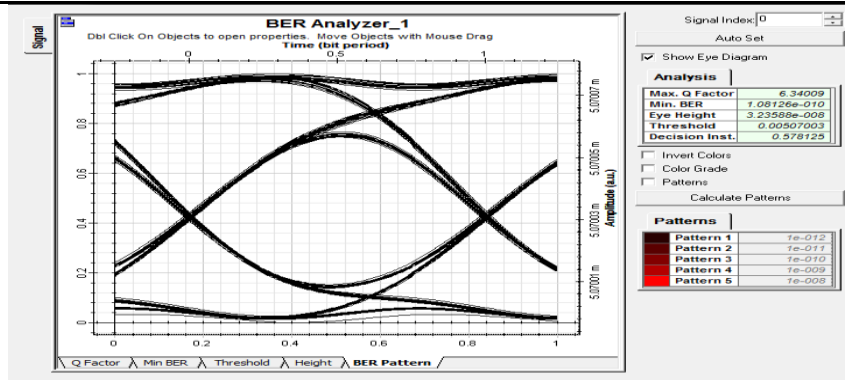

Fig.11. Eye Diagram for Receiver 2

For Receiver 2, the received signal has BER of 1.081E-010. The Q factor for the received signal is 6.340. Thus the BERanalyser shows that this receiver also received the good quality of the signal. Figure 10 and Figure 11 shows the Q factor result and Eye diagram for receiver 2 respectively.

Optical Input Power vs Q factor.

The variation of optical input power with respect to Q factor values was analysed for different fiber lengths 50 km, 75 km, 100 km. The graphical analysis of them was shown in the figure 12. By comparing the optical input power with Q factor values, it shows that the Q factor decreases as the length of the optical fiber increases which is shown graphically.

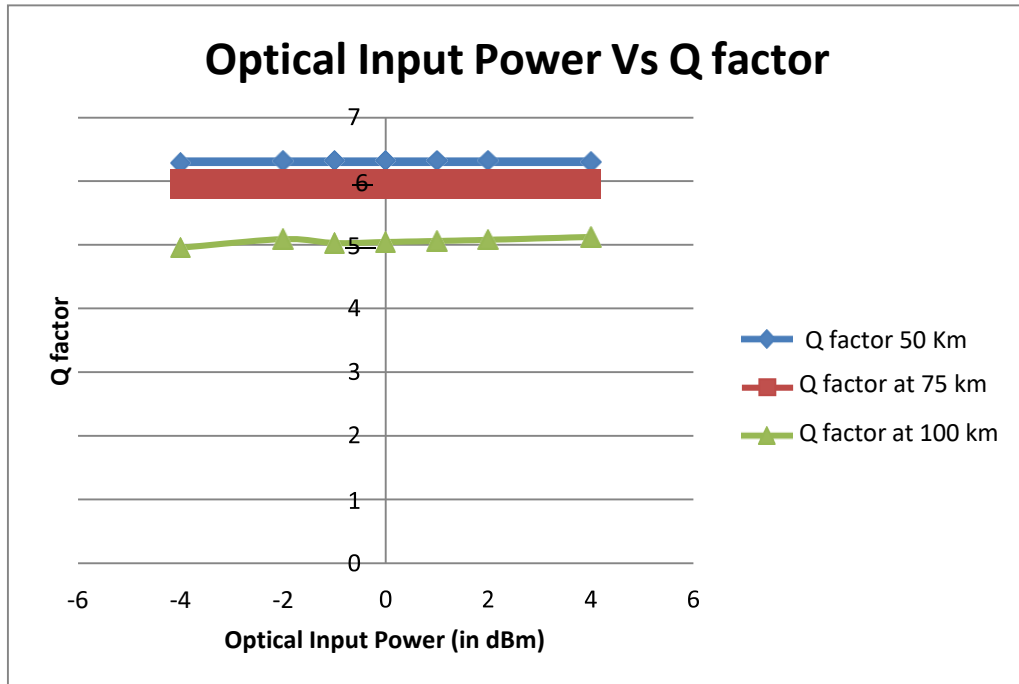

Fig.12. Optical Input Power versus Q factor

BER vs Q factor:

The value of BER is depending on the measurement time and factors lead to the error. The value of Q depends on the value of BER. Figure 13 shows the graph that indicates the relationship between BER and Q factor.

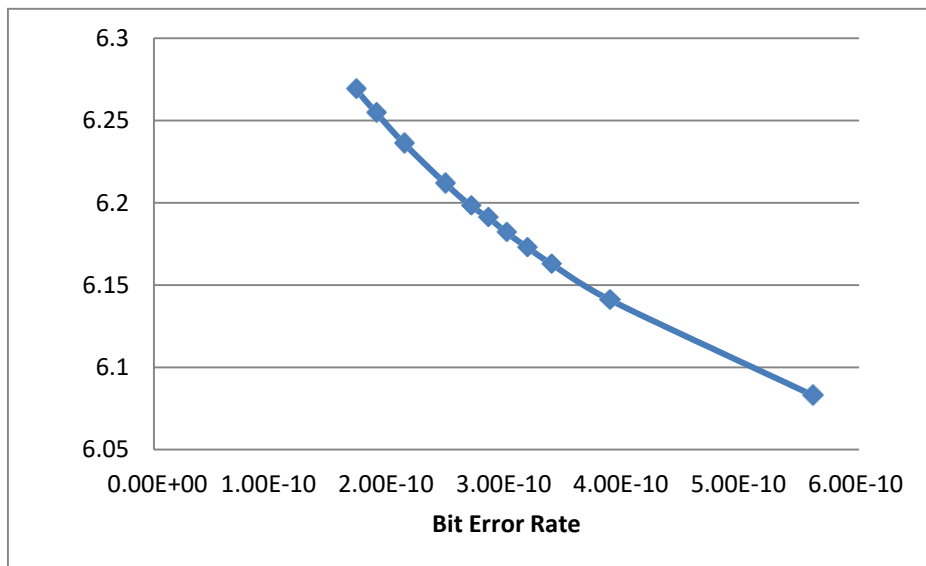

Fig.13. BER vs Q factor

The graph shows that the value of Q factor increases when the BER decreases. The ROF system should have a value of Q factor more than 6 in order to obtain a very good performance of its receiver. Hence the proposed system achieved a Q factor

morethan 6 with BER approximately E-10

VI CONCLUSION

The non linearity effects such as the signal loss for each channel have been corrected using the Optical amplifier in order to enhance the optical network performances. Thus the WDM Optical transmission system using the M-ary pulse amplitude modulated Radio over Fiber system was studied and designed. By integrating WDM with RoF network, an increase in bandwidth can be obtained but the use of WDM degrades the performance of the system because of production of non linear effects. The simulation results are presented to enhance the performance of 2-PAM modulated WDM ROF network.

REFERENCES

- [1] M.S. Kumar, Fundamentals of Optical Fibre Communication, 2nd Ed. India: PHI Learning Pvt. Ltd.,2014.
- [2] X. S. Qiu, Z. M. Tuo and Z. Yan, Millimeter Wave Technology in Wireless PAN, LAN and MAN, CRC Press,2008.
- [3] V. Sarup and A. Gupta, “A Study of various Trends and Enabling Technologies in Radio over Fiber (RoF) Systems,” Optik-International Journal for Light and Electron Optics, vol. 126, no. 20, pp. 2606-2611,2015.
- [4] M.Vidmar,“Optical-fiber Communications:Components and Systems,”INFORMACIJE MIDE M, vol.31,no.4,pp.246-251,2001.
- [5] A. Nirmalathas, P.A. Gamage, C. Lim, D. Novak and R. Waterhouse, “Digitized radio-over-fiber technologies for converged optical wireless access network,” Journal of Lightwave Technology, vol. 28, no. 16, pp. 2366-2375, 2010.
- [6] V. Sharma, A. Singh and A.K. Sharma, “Challenges to radio over fiber (RoF) technology and its mitigation schemes–A review,” Optik-International Journal for Light and Electron Optics, vol. 123, no. 4, pp. 338-342,2012.
- [7] C. Lim, A. Nirmalathas, K.L. Lee, D. Novak and R. Waterhouse, “Intermodulation distortion improvement for fiber–radio applications incorporating OSSB+C modulation in an optical integrated-access environment,” Journal of lightwave technology, vol. 25, no. 6, pp. 1602-1612,2007.
- [8] U. Gliese, S. Norskov and T.N. Nielsen, “Chromatic dispersion in fiber-optic microwave and millimeter-wave links,” IEEE Transactions on microwave theory and techniques, vol. 44, no. 10, pp. 1716-1724,1996